

Eisennäherungsschalter

Steel sensing proximity switches

Interrupteurs actionnés par métaux magnétiques

114 010

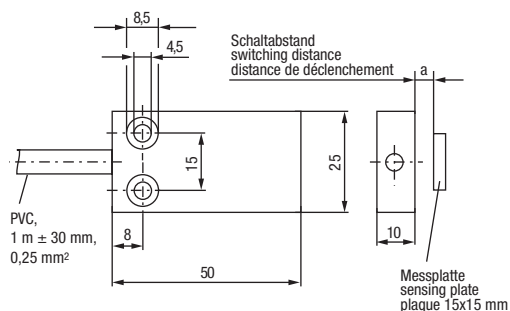

161 010

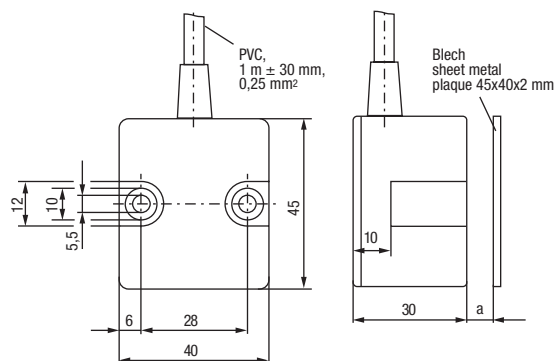

Typen Nr. type no. référence	Schaltspannung switching voltage tension de commut.	Schaltstrom switching current courant de commut.	Schaltleistung switching power pouvoir de coupure	Schaltabstand (a) switching distance (a) distance de déclenchement (a)
114 010	max. 48 V	max. 0,5 A	max. 10 W / 10 VA	≥ 4 mm mit Blech/with plate/avec plaque 15 x 15 x 2 mm
161 010				≥ 10 mm mit Blech/with plate/avec plaque 45 x 40 x 2 mm

Typen Nr. type no. référence	Kontaktform* contact form* type de contact*	Schutzart protection class protection	Temperaturbereich temperature range plage de température	Material material matériaux
114 010	A	IP 67	-25...+75°C	PA
161 010				

* A = Schließer
A = N.O.
A = NO